

BIKE BRANDING GUIDELINES

1. IMPORTING LOGOS / GRAPHIC ELEMENTS:

Import/place the vectorized (i.e., converted into paths) original image onto the bike sketch. Ideally your logo will be in AI, EPS, SVG or PDF format. In case of photo or image files we strongly recommend JPG or PDS files with 72 dpi in original size. (Please also refer to page 'Data Processing')

2. PRIMER / BIKE COLORS:

The base coat of your street food bike forms the foundation for your completely customised branding. For this, the entire bike frame is coated with a high-quality powder coating in standard anthracite grey or a RAL Classic colour of your choice; alternatively, for an additional charge, it can be finished with a robust triple-layer automotive paint in the colour of your choice (RAL / NCS). You can easily convert the specified colour code to CMYK yourself using an online converter and apply it as the body colour in the template on the PAINT/COATING layer for a perfect visualisation of your bike.

3. BIKE DESIGN:

When using BRANDING-PAKET-PRO we typically recommend placing the two larger logos (60 x 35 cm) on the client side (7) as well as the front side (2). The three smaller logos (40 x 25 cm) should be placed on the client side (7), the front side (2) and the cover flap or the vendor side (3). BRANDING-PAKET-PRO allows you to create logos and graphic elements as 360° cutout and print film coating. Please note that any texts placed on lids are upside-down when shut. Depending on the kind of bike selected (cooking/freezing inserts, CPI, CPI I, etc.) the size of the space available for branding on the vendor side varies significantly. PLEASE NOTE: As can be seen in the template, large parts of the surface area will be almost entirely covered when attaching a rattan basket. The same applies to certain other configurations such as added speed racks. We strongly recommend you refrain from placing important graphic elements in this area.

Your branding will be printed on 3M film - either with a silky matt or high gloss finish.

Interested in our professional support to brand your bikes? Our graphic design department offers a wide range of services from logo design to full service-packages. Feel free to reach out to our sales department to receive more information +43 1 36166100

4. HANDLING THE TEMPLATE:

The template offers a genuine dimensioning (1:7) of your bike. The separate layers organize printable and non-printable areas, offer optional bike upgrades and show exact dimensions. Using the Show/Hide function your bike can be displayed to your exact specifications.

The genuine dimensioning also allows you to see the final size of your logo/graphics and their resolution (use zoom at 100%). The layer BIKE-BASE COAT COLOR lets you to define the base color (see 2. above).

Once your street food bike has been successfully configured, save the final version as a PDF and send it (along with all supporting materials - please refer to page 'Data Processing') to graphic@paulandernst.com or the sales representative working directly with you.



BIKE BRANDING GUIDELINES

ad 3.) BIKE DESIGN:

PACKAGE BRANDING MEDIUM with 2 big logos and bike base coat of Your desired color



PACKAGE BRANDING MEDIUM with 3 smaller logos and bike base coat of Your desired color

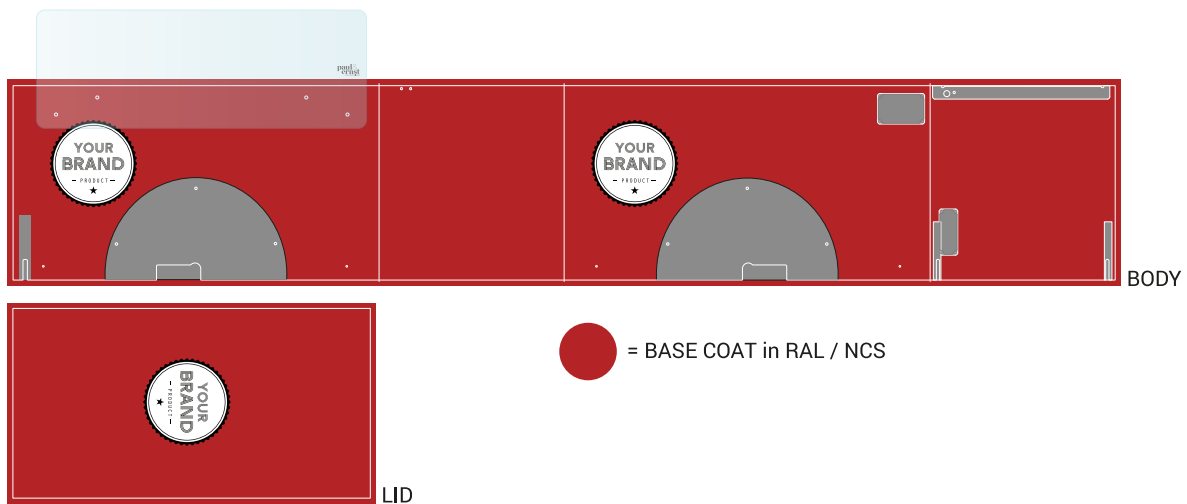

CUT OUTLINE / CUT CONTOUR and BLEED



CUT OUTLINE: CREATE A SEPARATE LAYER "CUTOUTLINE" USING A SOLID COLOR WITH STROKE WEIGHT 1 PT. BRING THIS LAYER IN FRONT OF LAYER "BLEED".

BLEED: DEFINE BLEED AS THE OUTERMOST COLOR TO THE EDGE AND SET BLEED AREA TO 3MM OR 10 PT. (DEPENDING ON YOUR GRAPHIC ELEMENTS) TO AVOID WHITE RIMS AFTER LASER CUTTING. CREATE SEPARATE LAYER 'BLEED'.

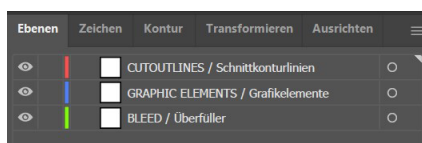

BIKE BRANDING GUIDELINES

ad 3.) BIKE DESIGN USING OUR ADOBE ILLUSTRATOR TEMPLATES:

Your sales representative will provide you with a realistic template in AI format for the graphic design of your customised bike, pushcart or trailer, as well as for parasols and/or beach flags. In the LAYERS window, you can define your desired configuration at the start of the design process by displaying the add-ons you have ordered (orange layer marker). This allows you to see what your personalised bike looks like and which areas on the frame remain free for design. Now activate the 'PAINT/Lackierung' layer and select the base colour for the frame. On the "Place here: YOUR DESIGN" layer, place the logos/graphics as vectors in the CMYK colour space (fonts converted to paths!), with 2 or 3 logos depending on the branding package ordered, or the full design in the Branding LARGE package. Finally, save your design as an AI file and send it to us via WeTransfer to graphic@paulandernst.com

PRINTING PROOF - BIKE ICE CREAM
DESIGN APPROVAL / ORIGINALSIZE
GUT ZUM DRUCK - BIKE-DESIGN-FREIGABE / 1:1

IMPORTANT FOR GRAPHIC DESIGNERS:
Please check which add-ons have been ordered before designing, as these affect the visibility of the designs. If necessary, show or hide ADD ON/OFF orange layers.

WICHTIG FÜR GRAFIKER:INNEN:
Bitte informieren Sie sich vor der Gestaltung welche Addons bestellt wurden, da sich diese auf die Sichtbarkeit der Designs auswirken. Blenden sie gegebenenfalls die orangen ADD ON/OFF - Ebenen ein oder aus.

PRINTING PROOF - PUSH CART BIG ICE CREAM
DESIGN APPROVAL / ORIGINALSIZE
GUT ZUM DRUCK - PUSH CART DESIGN-FREIGABE / 1:1

IMPORTANT FOR GRAPHIC DESIGNERS:
Please check which add-ons have been ordered before designing, as these affect the visibility of the designs. If necessary, show or hide ADD ON/OFF orange layers. Blenden sie gegebenenfalls die orangen ADD ON/OFF - Ebenen ein oder aus.

PARASOL DESIGN TEMPLATE / SCHIRMGESTALTUNGS VORLAGE
SEE INFO ON THE A4 SHEET / SIEHE INFOS AUF DEM A4



BIKE SKETCHES · Template Downloads:
www.paulundernst.com/download-area

BRANDABLE AREAS
 GESTALTBARE FLÄCHEN

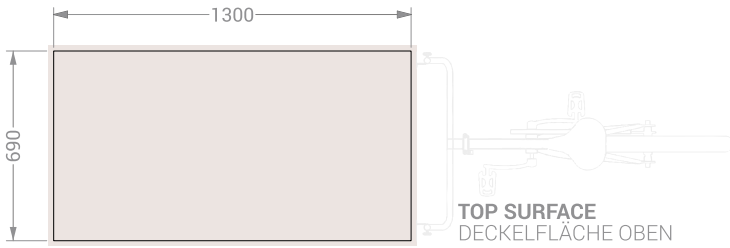

SPEED RACK / 8 BOTTLES
 FOR ALL BIKE MODELS
 EXCEPT CB PRO I + II

SPEED RACK / 6 BOTTLES
 FOR ALL BIKE MODELS
 EXCEPT CB PRO II



LID SURFACE
 KLASSE SEITENFLÄCHEN

CASH REGISTER
 R1, R2, R3

CUP DISPENSER

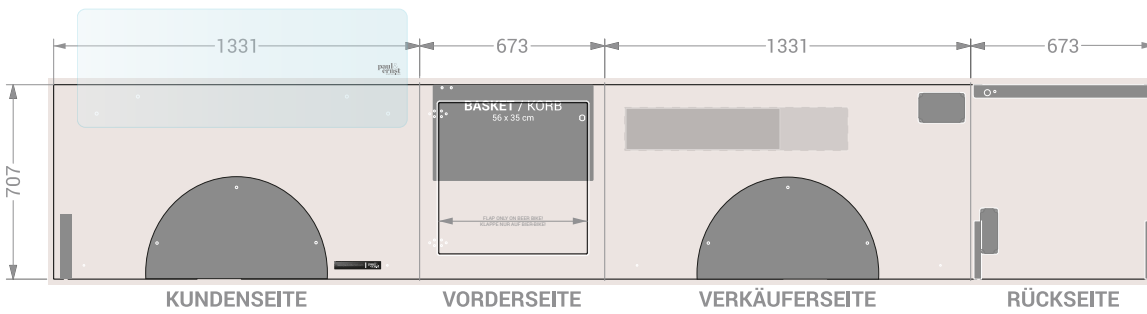

BODY / STREET FOOD BIKE:
PROMOTION
 COOKING BASIC
 BEVERAGE / BEER

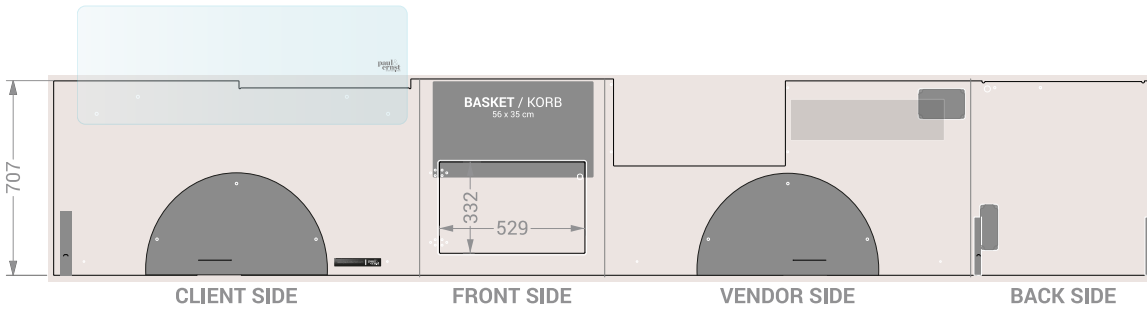

BODY / STREET FOOD BIKE:
COOKING PRO I

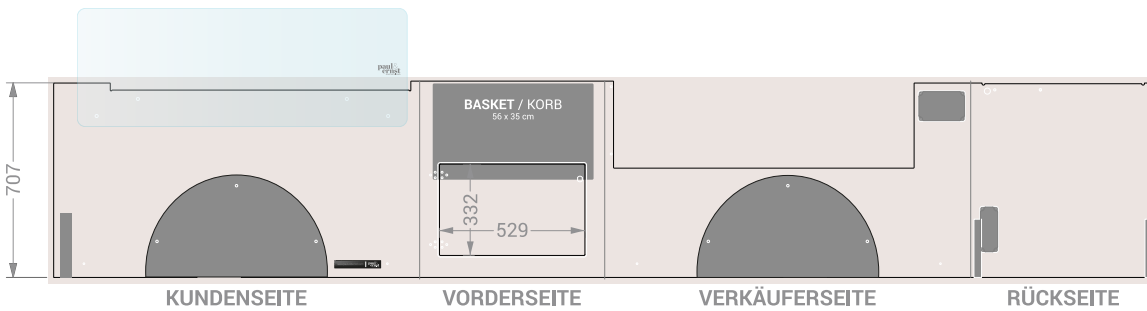

BODY / STREET FOOD BIKE:
COOKING PRO II

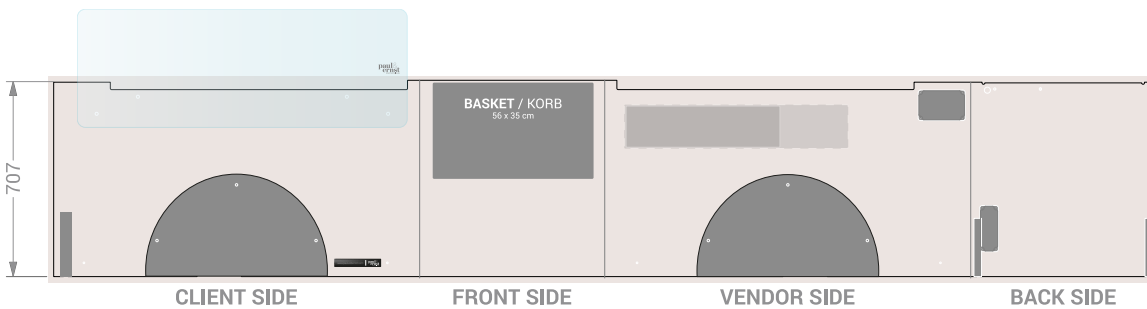

BODY / STREET FOOD BIKE:
ICE CREAM SQUARE
 ICE CREAM POZZETTI



TRAILER SKETCHES

BRANDABLE AREAS
GESTALTBARE FLÄCHEN

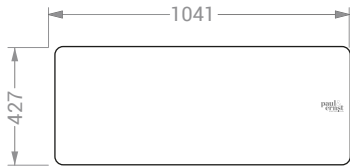

GLASS SPIT-PROTECTION
GLAS-SPUCKSCHUTZ

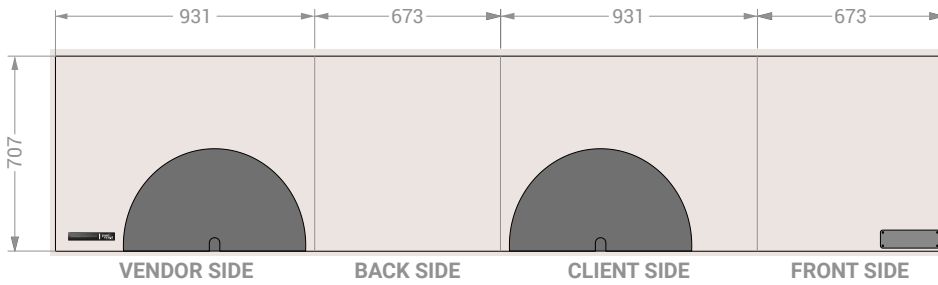

BODY:
TRAILER SMALL

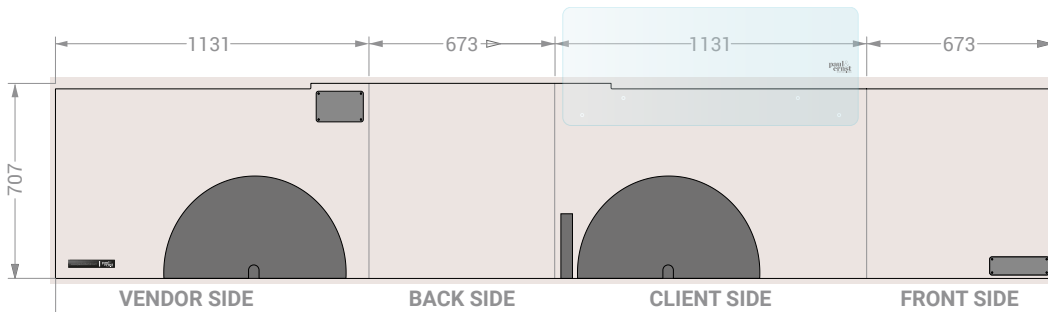

BODY:
TRAILER ICE CREAM

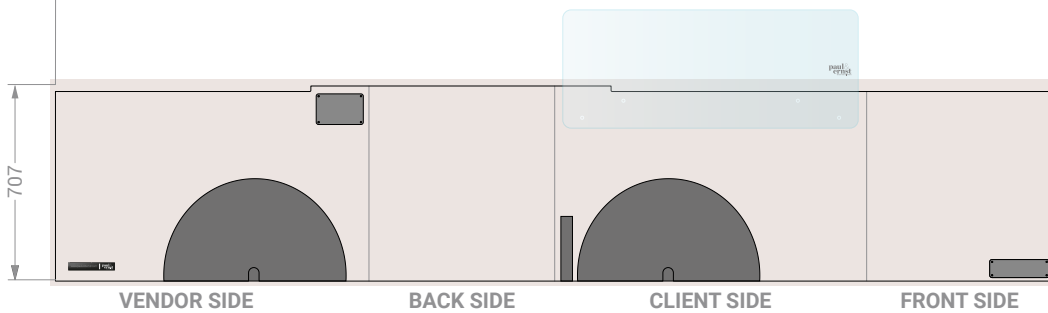

BODY:
TRAILER BASIC



BIKE VIEW CLIENTSIDE

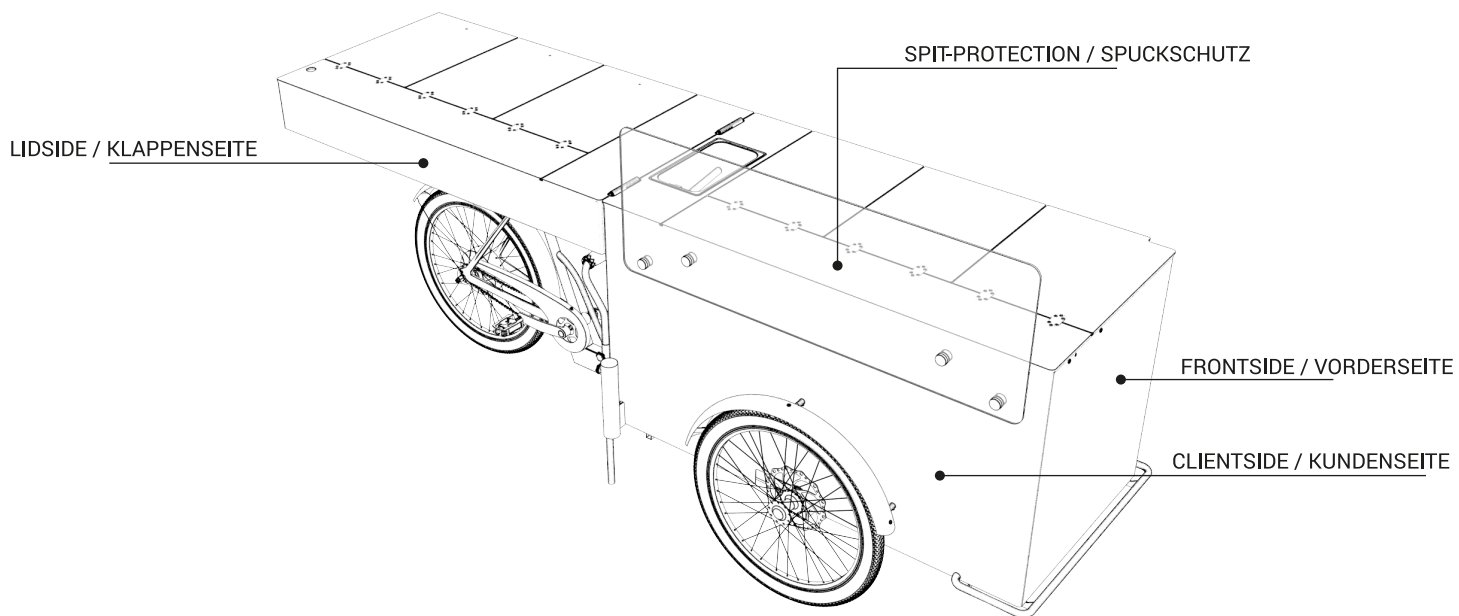

BIKE VIEW VENDORSIDE

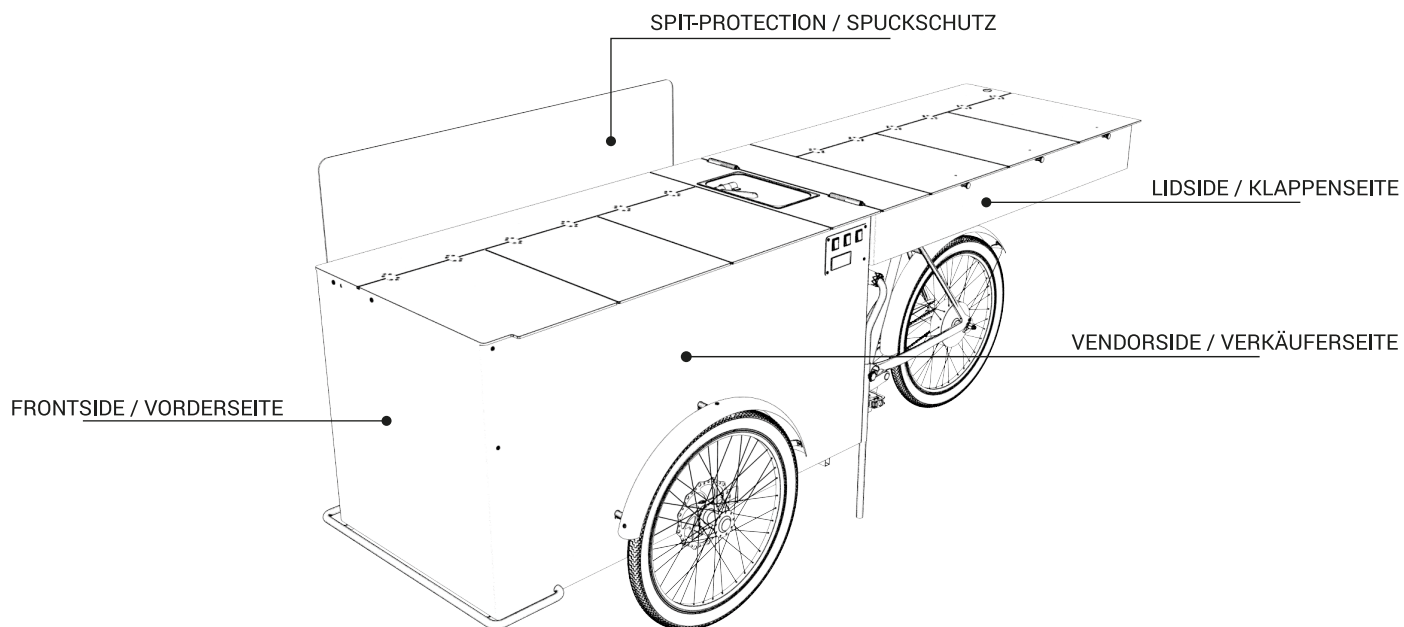

PARASOL

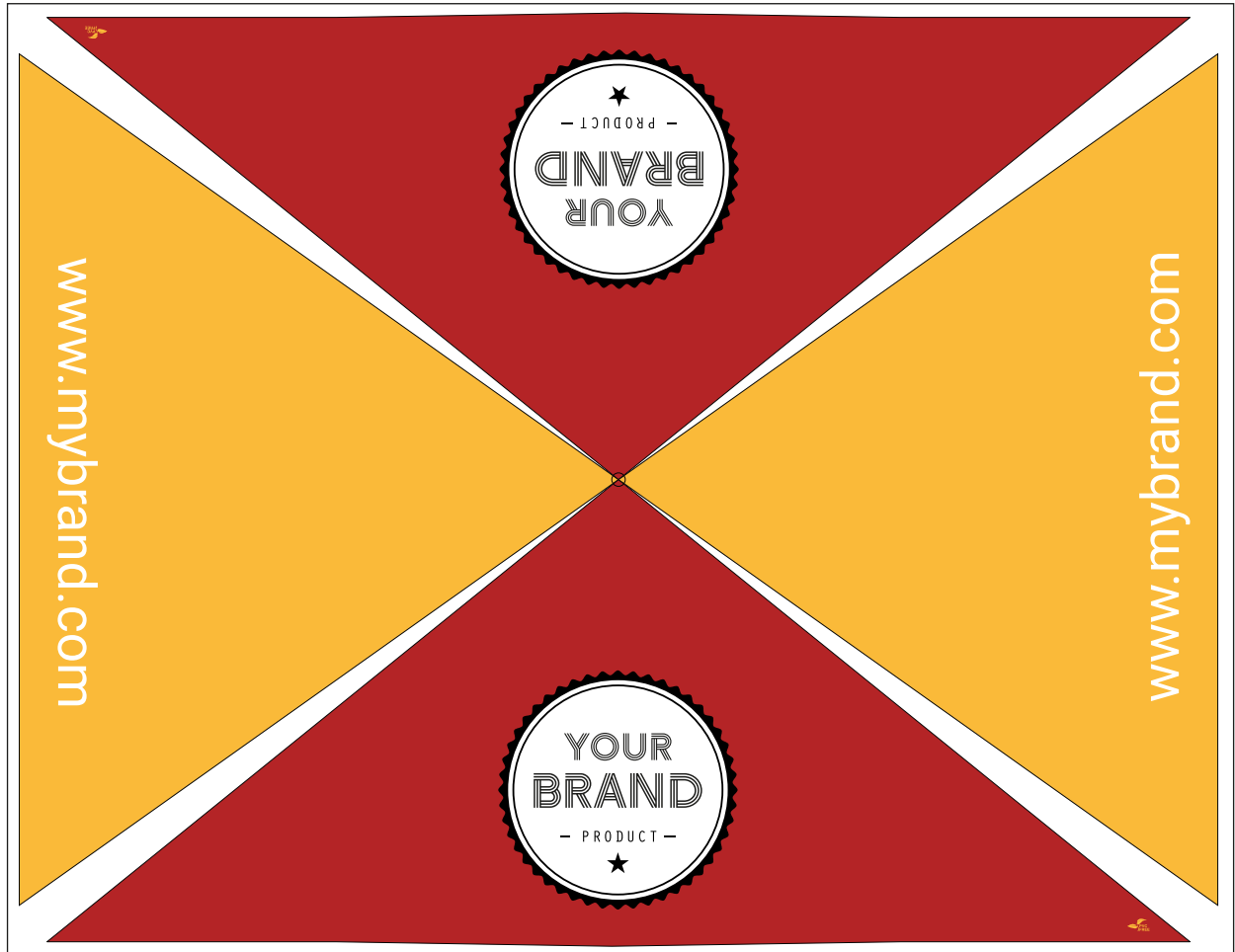

Would You like to design the parasol for Your street food bike yourself? We would be delighted to share a 1:1 template including branding guidelines with You, or download the template on www.paulandernst.com/download-area. Our graphic design department will gladly assist You with any print-related questions: graphic@paulandernst.com

BEACH FLAGS

TYP DROP STANDARD - S / M / L:

SMALL: visible area = 1910 x 696 mm (H/W) final size incl. hemstitch = 2020 x 762 mm (H/B)

MEDIUM: visible area = 2750 x 1020 mm (H/W) final size incl. hemstitch = 2845 x 1070 mm (H/B)

LARGE: visible area = 3935 x 1080 mm (H/W) final size incl. hemstitch = 4120 x 1144 mm (H/B)

Would You like to design the beach flag for Your street food bike yourself? We would be delighted to share a 1:1 template including branding guidelines with You, or download the template on www.paulandernst.com/download-area. Our graphic design department will gladly assist You with any print-related questions: graphic@paulandernst.com

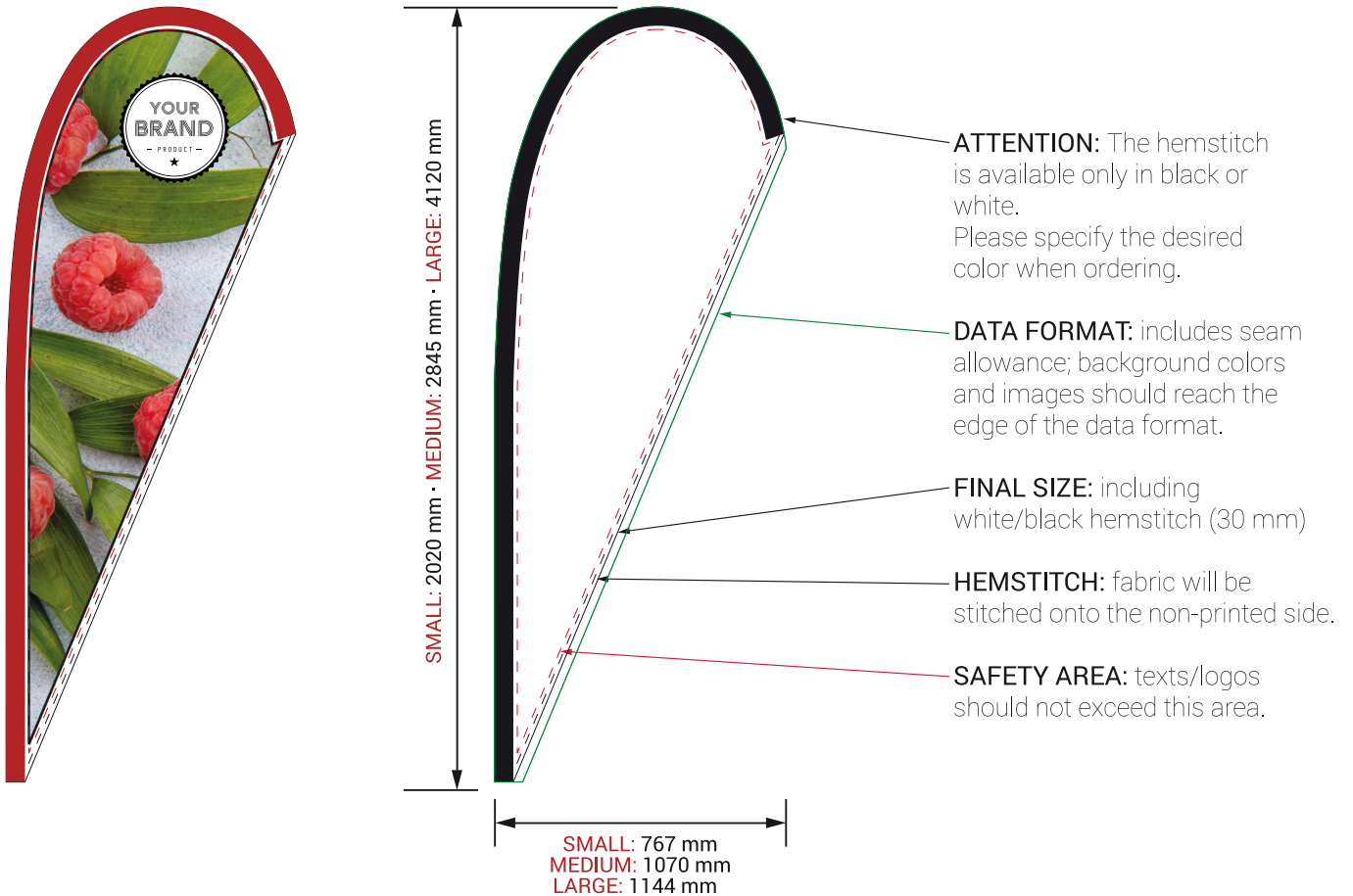

COVER / STORAGE COVER

To cover Your street food bike we offer a weatherproof and brandable cover garage. Please contact the sales team with any questions or suggestions You may have.

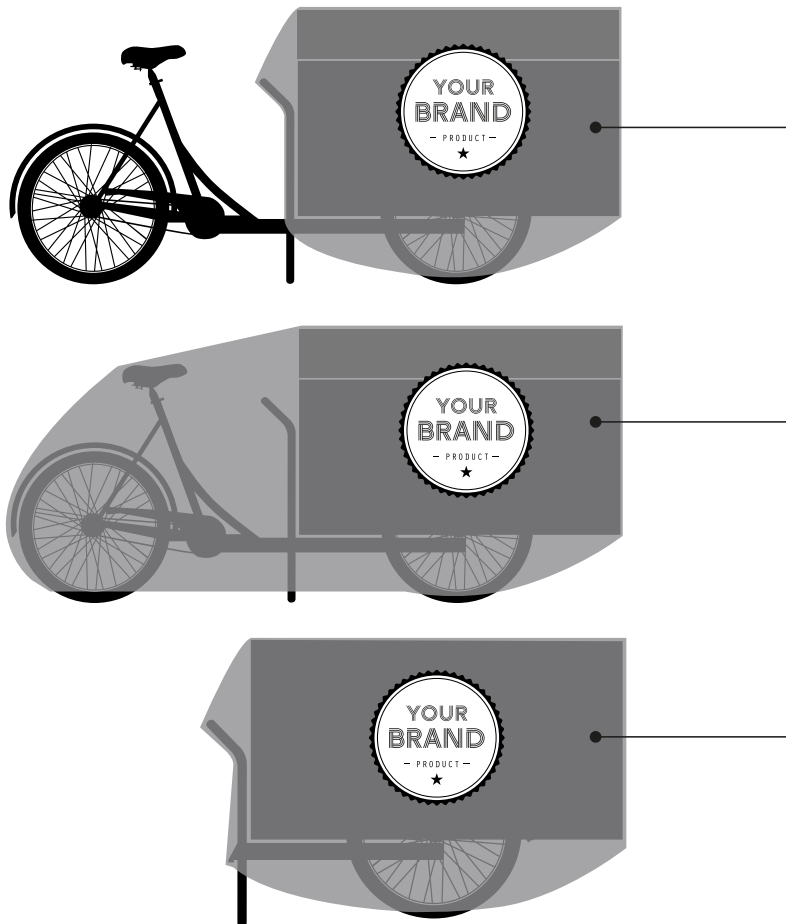

COVER ON DEMAND
(Depends on material, print,
cover with / without basket,
trailer cover, etc.)



DATA PROCESSING

FORMAT / RESOLUTION:

Lid (L,W,H): 1330 x 690 x 160 mm

Body (L,W,H): 1330 x 690 x 687 mm

Please add image files at a 1:1 scale and a resolution of at least 75 dpi and submit as PSD or PDF files. We accept vector graphics in PDF, AI or EPS format.

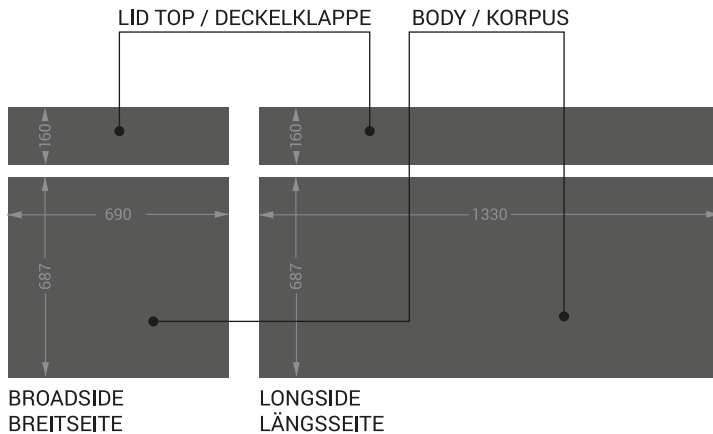

COLOR MANAGEMENT:

We use CMYK (four-printed colors) color mode for all our printed products. Spot colors such as Pantone, RAL or HSK are therefore only possible within the CMYK color range. Unfortunately, print color accuracy with RGB colors cannot be guaranteed. If you choose to use spot colors in your files, we kindly ask you to inform your sales representative upon ordering.

FONTS / IMAGES:

ATTENTION! All fonts (including fonts embedded in logos) need to be converted into paths (vectors). All images, logos and fonts need to be supplied along with your print materials.

CONTOUR CUTTING AND WHITEPRINT:

Are you interested in using contour cutting or whiteprint for your print work? Please note that individual color channels/layers need to be created as spot colors. The color channel for whiteprint should be named 'WhiteU', the color channel for cutlines should be labeled as 'CutContour' – both channels need to be set to 'overprint'. The assigned color can be chosen freely. When choosing this option, DF or EPS / AI data files are absolutely essential.

Plotting: Only vector graphics can be plotted. All fonts and objects need to be converted into paths. Lines need to be rendered as shapes (not as contours/line width). You will again have to create your own cut contour lines and bleeds. The smallest possible uppercase height is 10 mm.

You can design the bike using our template, but are unable to create the print files yourself, including cut-out lines and bleed areas? We'd be happy to do this for you for a small additional charge.

Our graphics department is also on hand to assist with any printing-related queries:

graphic@paulandernst.com.

