

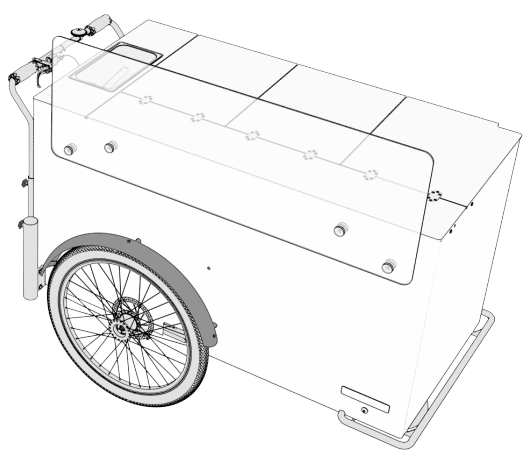

# P&E DATASHEET 2024 PUSHCART BIG BASIC

P&E MODEL:	PUSHCART BIG BASIC
REFRIGERANT:	R290
TARE WEIGHT:	150 kg
TOTAL WEIGHT:	250 kg



### BASIC SETUP:

available without or with cooling unit of 240 liters; available with or without water system (2 x 14 liters of fresh/waste water)

### PUSHCART BIG:

steel frame including metal casing for battery and electronics; stainless steel handlebar; hydraulic disc brakes with parking brake feature

