

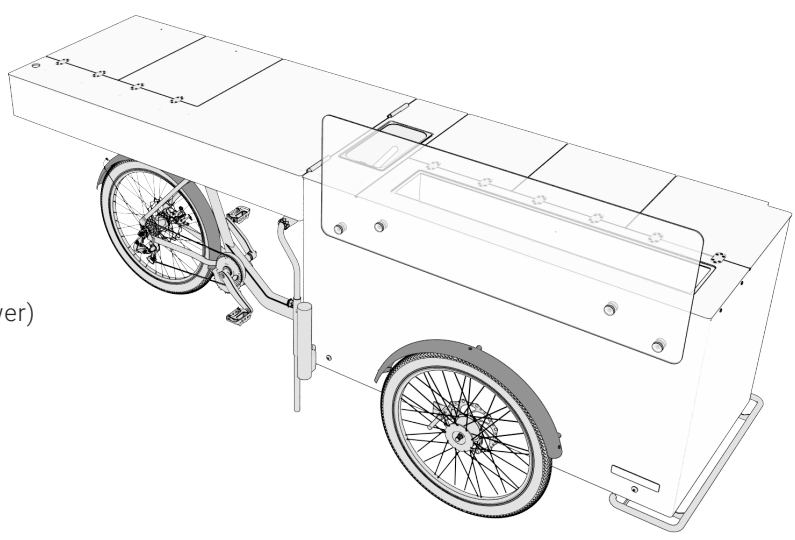

P&E DATASHEET 2024 BEVERAGE BIKE

P&E MODEL:	BEVERAGE BIKE
E-BIKE DRIVE:	250 Watt (Rated Power)
REFRIGERANT:	R290
TARE WEIGHT:	175 kg
TOTAL WEIGHT:	380 kg



BEVERAGE SETUP:

paul&ernst 240-liter cooling unit; cooled bottle tub made of stainless steel; cooling unit may be equipped with GN rails

E-CARGO-BIKE:

pedal-assist system with 500 watt E-Cargo motor (250 watt rated power); 11-speed Shimano Deore/XT chain gears; Magura Big Twin hydraulic disc brakes

